

IHI

CCH1500E

lifting capacity: 150 tons

*Fully hydraulic
Crawler Crane*

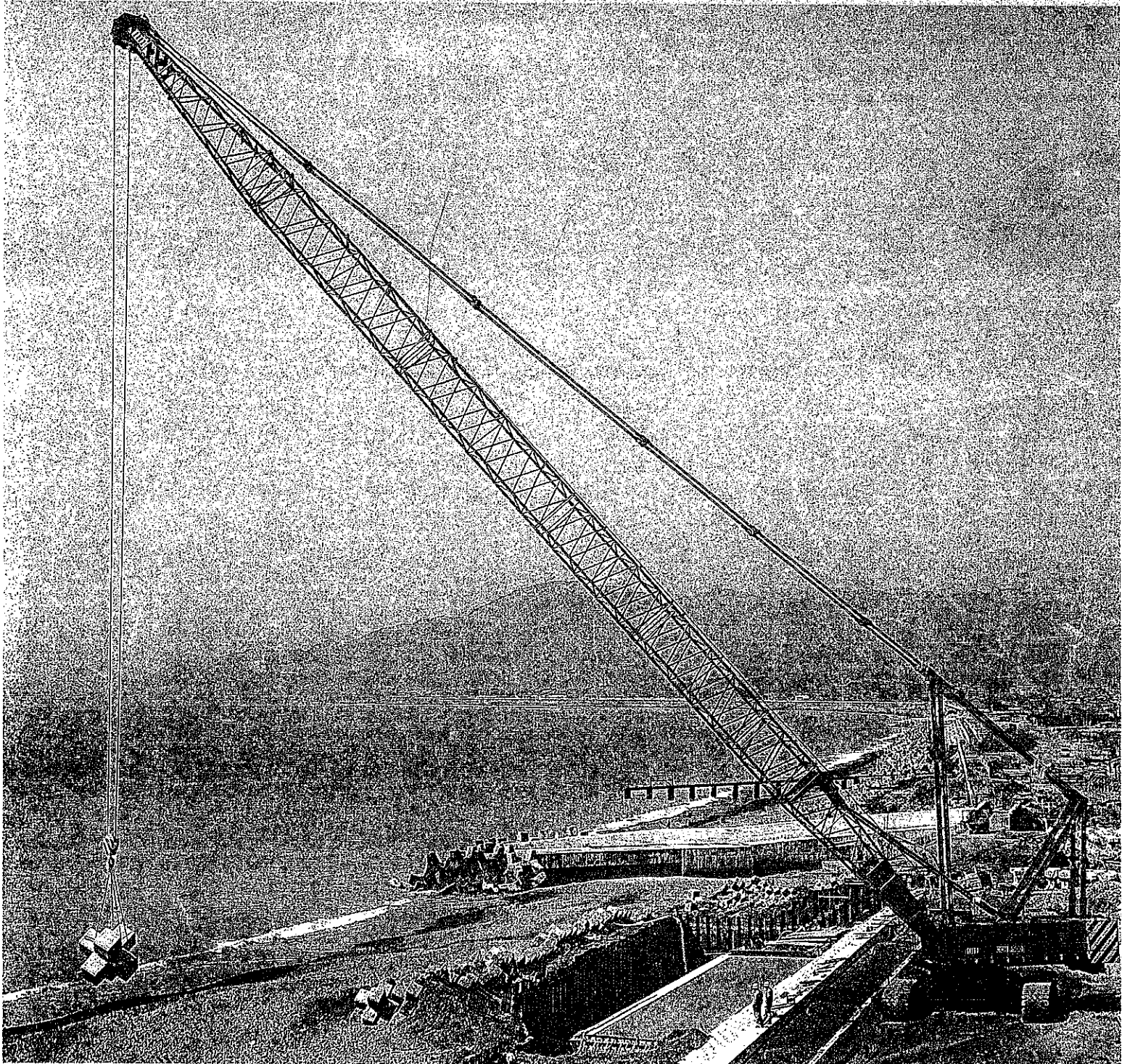

Ishikawajima Construction Machinery Co., Ltd.

CCH1500E

A big-job machine with top hydraulic power, performance & reliability!

The CCH 1500E is a super-heavy-duty, fully-hydraulic crawler crane developed for big-project operations. Its large lifting capacity of 150 tons provides powerful, efficient performance in large-scale operations such as plant and port construction projects. The crane employs optimum mechanisms as a super-heavy-duty type for its load hoisting system, boom hoisting system and cab unit, and incorporates a complete range of safety devices.

High power and excellent maneuverability

A high-power, diesel engine developing an output of 275 PS at 2,000 rpm is employed. Variable displacement plunger pumps with constant power control devices are used for hoisting, traveling, and boom hoisting operations, facilitating combined maneuvering. The control levers for hoisting, boom hoisting, swinging, and traveling are all designed to operate the main valves by way of remote control valves, so that only minimum effort is required for maneuvering.

Fully hydraulic control facilitating delicate operations

The load hoisting/lowering, swinging, and boom hoisting/lowering are performed by independent hydraulic drive systems. Due to the adoption of remote control valves, these movements can be carried out smoothly. The speeds of each movement can be adjusted steplessly by control lever.

Smooth brake operation

The hoisting brake is hydraulically assisted for smooth operation, and in particular features excellent inching operation. The foot brake pedal system and the automatic brake system can be selected by a switch.

Boom hoisting/lowering winches ensuring sway-free operation

The double-drum on one-shaft arrangement minimize the sway of the boom point during boom hoisting/lowering operation.

Smooth swinging

The slewing ring is of ball bearing type to ensure sway-free smooth swing even at times of starting and stopping. Swing

speed can be set to either high or low. The disc brake system ensures control of swing speed during free swing operation and can easily prevent the superstructure from moving on a slope.

Traveling system with easy turning

Each crawler is driven by an independent hydraulic motor, making possible easy pivot-turning and quick spin-turning. The traveling brake is automatically applied whenever its control lever is positioned in neutral.

Rigid boom

The boom is of tubular construction made of high-tensile steel. The 18m basic boom (lifting capacity: 150 tons) can be extended up to 81m by addition of inserts. A fly jib can also be attached in lengths of 13 to 31m, enabling the boom to be extended up to a maximum of 100m.

Independent cab with maximum operator's comfort

The cab is completely independent of the machine room and shielded against noise and vibration. Glass windows on five sides, a rearview mirror, and a ceiling wiper ensure excellent visibility. Special consideration has been given to the lever arrangement, foot space and the instrument lay-out to minimize operator fatigue, and a reclining seat is also provided. The cab is thus specially designed for maximum operator's

comfort and ease controllability.

Complete range of safety measures

The CCH1500E is equipped with the following complete safety devices. Should the hydraulic circuit (hoisting, boom hoisting, traveling, etc.) be interrupted the check valves function to prevent an accident. Safety devices: Overload prevention device (moment limiter...Option), automatic boom overhoisting stopper, automatic hook overwinding stopper, telescopic boom limit stopper, main/auxiliary drum locks (ratchet type), boom hoisting drum lock (ratchet type), swing parking brake, 4-way swing lock, load fall prevention alarm.

Simple DISMANTLING convenience

The CCH-1500E crawler can be self dismantled to permit convenient transportation.

Complete safety features computerized moment limiter functions (option)

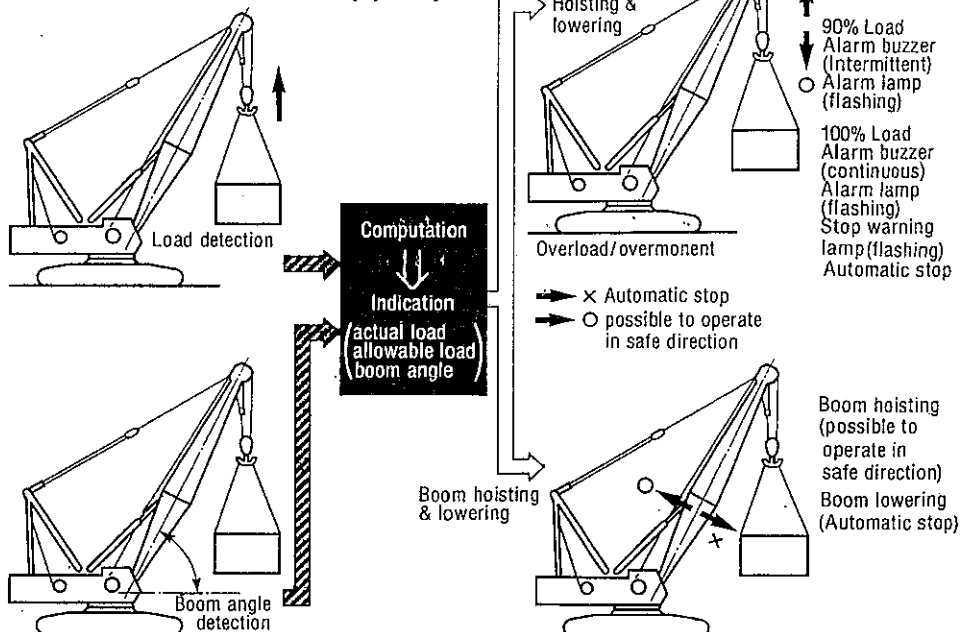

Hydraulic crane mechanism

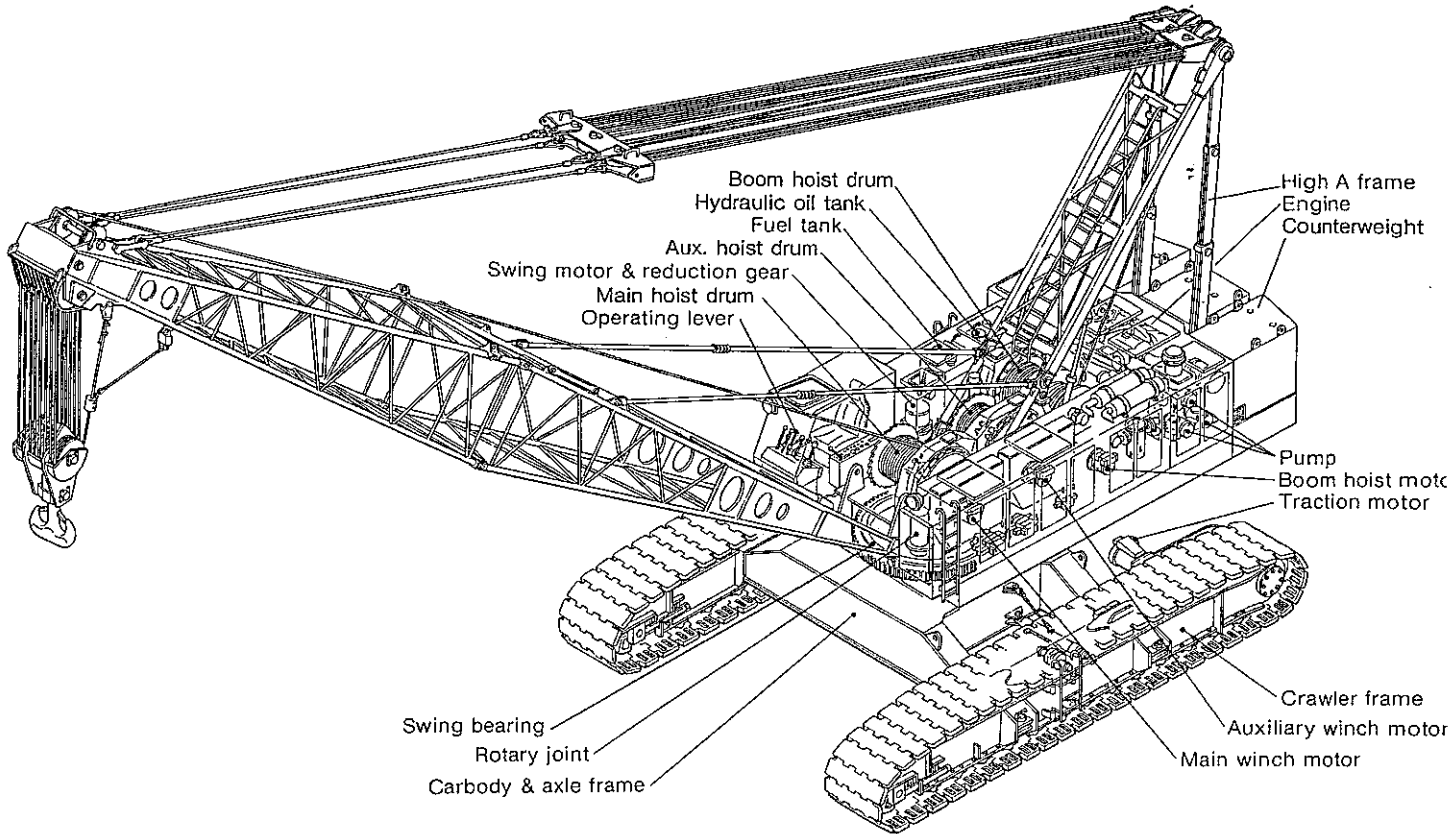

Crawler self dismantling method for convenient transportation

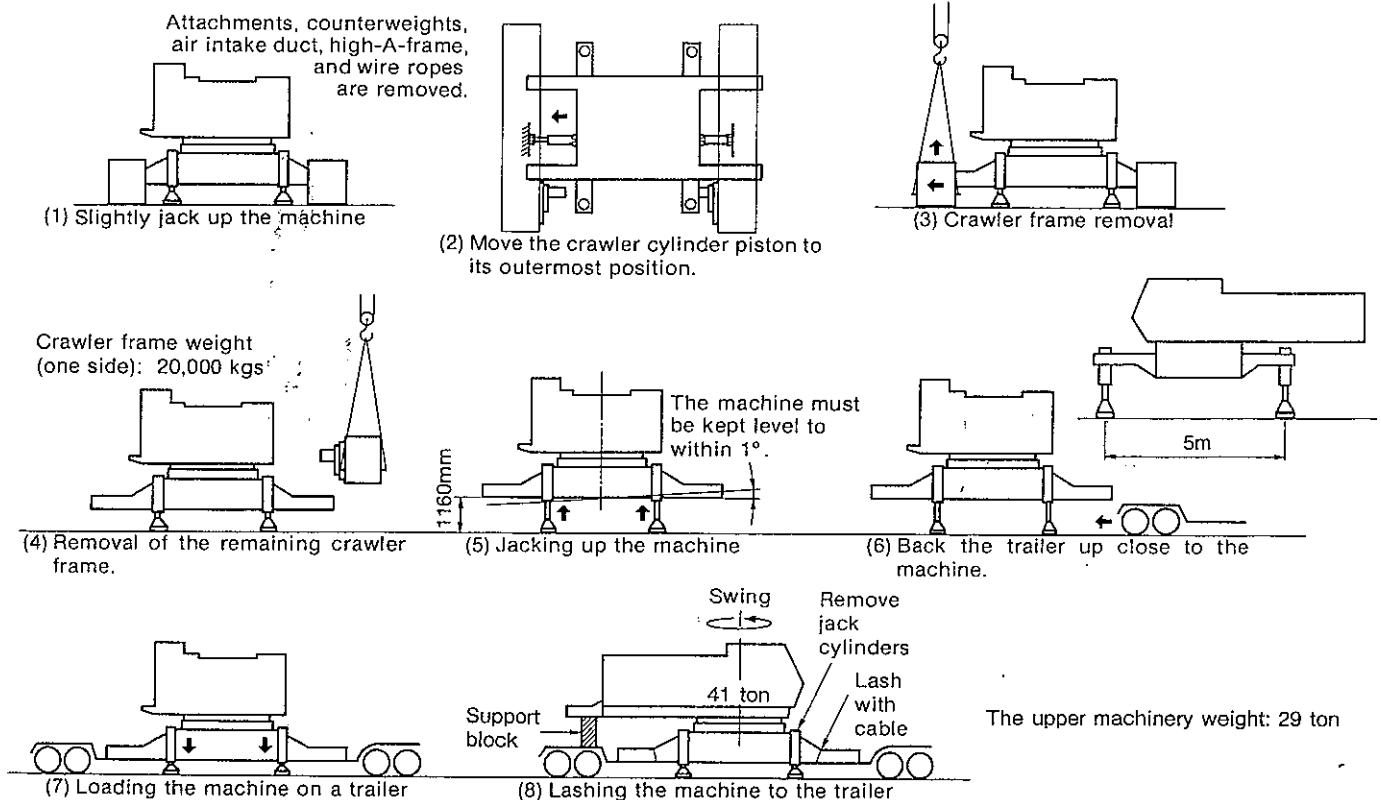

Specifications

Performance

Swing speed	High 2.0 / Low 1.3rpm
Travel speed	High 0.9 / Low 0.5km/h
Gradeability	30%

Hydraulic equipment

Hydraulic pump	Load hoist and traction	Variable displacement plunger × 2
	Boom hoist	Variable displacement plunger
	Swing	Fixed displacement tandem gear
	Control	Fixed displacement gear
Control valve		Remote control valve and hydraulic pilot multi valve
Hydraulic motor	Load hoist	Axial plunger X 2
	Boom hoist	Axial plunger
	Swing	Axial plunger
	Traction	Axial plunger × 2

Engine

Maker	HINO MOTORS
Model	EF750
Type	4-cycle, water-cooled, overhead valve Direct-fuel injection type
Cylinder-Bore × Stroke	V8-137mm X 142mm
Rated output	275ps/2,000rpm
Total displacement	16.745 ℓ
Max. torque	112kg-m/1,400 rpm
Fuel consumption ratio	168gr/ps-h
Starting unit	24V X 7.0kW Electric motor
Air cleaner	Paper type, cyclo cleaner
Generator	AC24V × 35A
Battery	12V × 150Ah × 2pcs.
Fuel tank capacity	400ℓ

General Dimensions (Unit: mm)

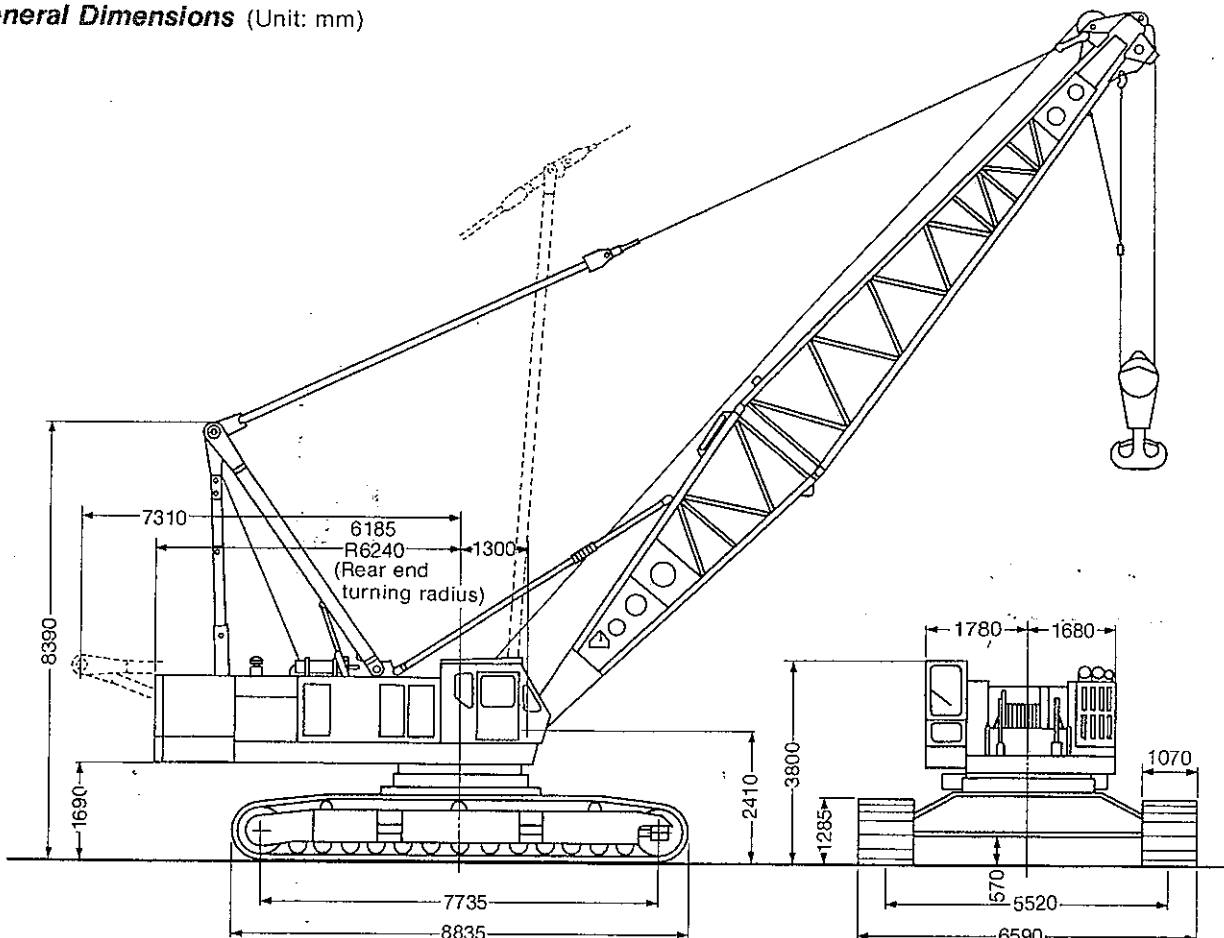

Crane

Working range

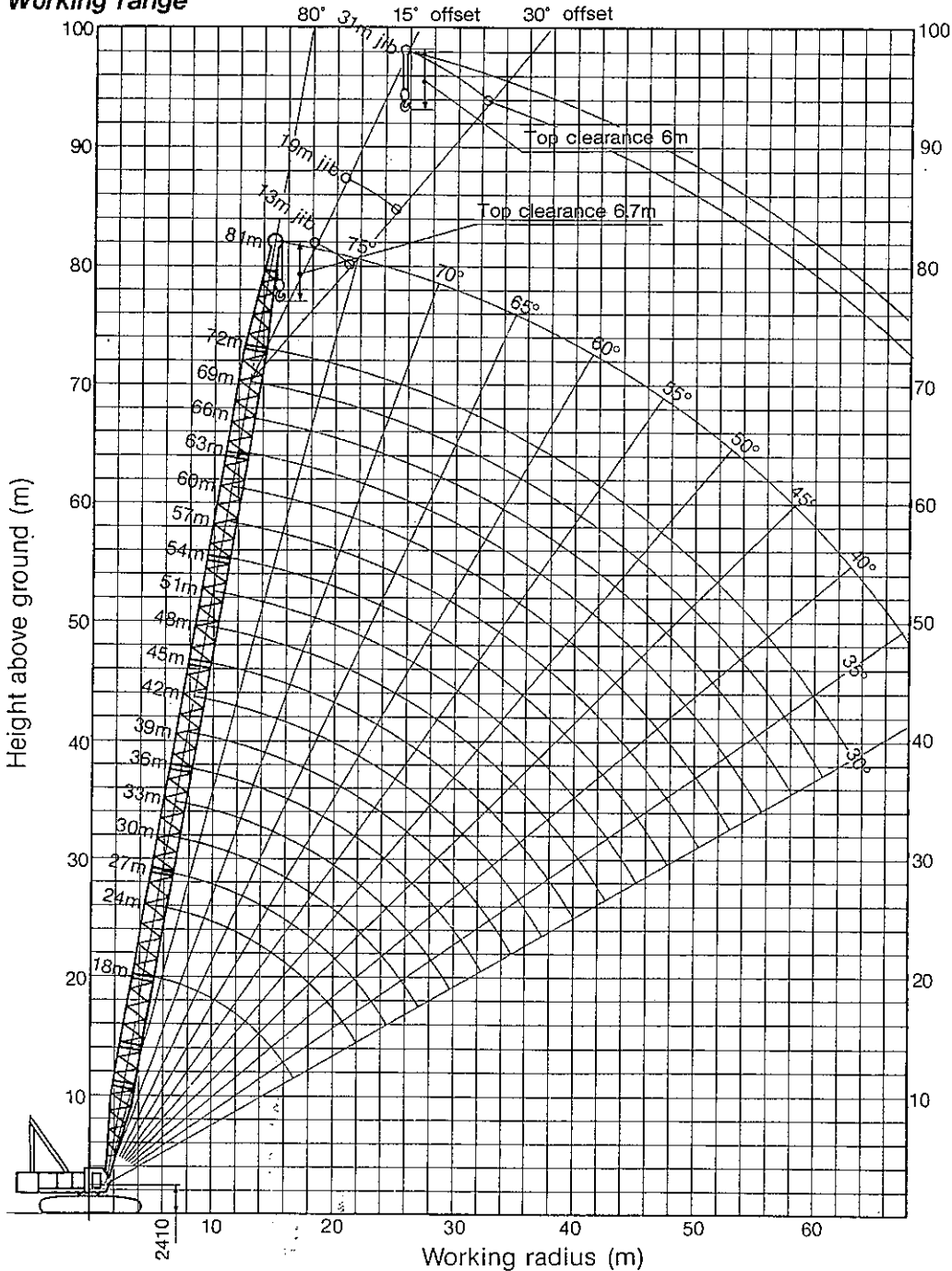

Boom compositions

This chart is max. 81m using 12m insert boom Unit:

Boom length	Main boom compositions		
	Inner	Insert	Outer
18	7.5		10.5
24	7.5	⑥	10.5
27	7.5	9	10.5
30	7.5	12	10.5
33	7.5	⑥, 9	10.5
36	7.5	⑥, 12	10.5
39	7.5	9, 12	10.5
42	7.5	12, 12	10.5
45	7.5	⑥, 9, 12	10.5
48	7.5	⑥, 12, 12	10.5
51	7.5	9, 12, 12	10.5
54	7.5	12, 12, 12	10.5
57	7.5	⑥, 9, 12, 12	10.5
60	7.5	⑥, 12, 12, 12	10.5
63	7.5	9, 12, 12, 12	10.5
66	7.5	12, 12, 12, 12	10.5
69	7.5	12, 12, ⑥, 9, 12	10.5
72	7.5	12, 12, ⑥, 12, 12	10.5
81	7.5	12, 12, ⑥, 9, 12, 12	10.5

⑥ denotes 6m insert boom w/lug: which is required for boom length over 69m.

Jib boom length	Jib boom compositions		
	Inner	Insert	Outer
13	4.5	3	5.5
19	4.5	9	5.5
31	4.5	3, 9, 9	5.5

Boom & Jib composition

○: Applicable

Jib length (m)	Boom length (m)											
	18~42	45	48	51	54	57	60	63	66	69	72	81
1.5	○	○	○	○	○	○	○	○	○	○	○	
13		○	○	○	○	○	○	○	○	○		
19		○	○	○	○	○	○	○	○			
31		○	○	○	○	○	○	○	○			

Crane specifications

Max. lifting capacity × Working radius		150 metric ton × 5.0m
Max. lift above ground		93m (69m + 31m)
Basic boom length		18m (7.5m + 10.5m)
Boom length		18m to 81m
Max. length of boom with fly jib		100m (69m + 31m)
Fly jib length		13m, 19m, 31m
Rope Speed	Boom hoist/lowering	**21m/min
	Load hoist/lowering	**80/40/20m/min
	Jib load hoist/lowering	**80/40/20m/min
Part line	Boom hoist/lowering	8 part line × 2
	150 ton hook block	16 part line
	13 ton hook block	2 part line
Counterweight		50.0t
Total operating weight*		Approx. 147.0t

*With 18m basic boom and 150 ton hook block

**Rope speed will be changed according load factor.

Wire rope

	Rope Type*	Rope dia. (mm)	Guaranteed strength (t)
Load hoist	A	26	58.0
Boom hoist	B	20	34.1
Boom suspension	C	34	86.7
Jib load hoist	A	26	58.0
Jib suspension	D	28	59.3
Jib strut suspension	D	28	59.3
Intermediate suspension	C	20	30.0

*Rope type "A": 3×F(a+40), mono-rope EP

Rope type "B": T7×7+6×Fi(29) IWRC

Rope type "C": 6×Fi(29) IWRC regular Z lay

Rope type "D": 6×Fi(25) IWRC regular Z lay

Rated lifting loads

(Unit: metric ton)

Working radius (m)	Boom length (m)																		
	18	24	27	30	33	36	39	42	45	48	51	54	57	60	63	66	69	72	81
5	*150.0																		
6	*140.0																		
7	123.4	123.1	123.0																
8	98.8	98.5	98.4	98.3	98.2														
9	82.2	81.9	81.8	81.7	81.6	81.5	81.3												
10	70.2	69.9	69.8	69.7	69.6	69.5	69.3	69.2	69.0										
12	54.1	53.8	53.7	53.6	53.5	53.4	53.2	53.1	52.9	52.8	52.7	52.5	47.0						
14	43.7	43.4	43.3	43.2	43.1	43.0	42.8	42.7	42.5	42.4	42.3	42.1	39.0	37.4	34.7	32.0	31.6		
16	36.5	36.2	36.1	36.0	35.9	35.8	35.6	35.5	35.3	35.2	35.1	34.9	34.3	33.5	30.9	28.4	28.0	27.7	21.0
18	^{17m×} _{33.7} 30.9	30.9	30.8	30.7	30.6	30.5	30.3	30.2	30.0	29.9	29.8	29.6	29.2	29.0	27.5	26.0	25.6	25.3	20.0
20		26.8	26.7	26.6	26.5	26.4	26.2	26.1	25.9	25.8	25.7	25.5	25.2	25.0	24.2	23.5	23.1	22.8	19.0
22		23.6	23.5	23.4	23.3	23.2	23.0	22.9	22.7	22.6	22.5	22.3	22.1	22.0	21.8	21.5	21.1	20.8	17.7
24			20.8	20.7	20.6	20.5	20.3	20.2	20.0	19.9	19.8	19.6	19.5	19.4	19.2	19.1	18.7	18.4	16.2
26				18.6	18.5	18.4	18.2	18.1	17.9	17.8	17.7	17.5	17.4	17.3	17.1	17.0	16.6	16.3	14.7
28					16.7	16.6	16.4	16.3	16.1	16.0	15.9	15.7	15.6	15.5	15.3	15.2	14.8	14.5	13.5
30					15.1	15.0	14.8	14.7	14.5	14.4	14.3	14.1	14.0	13.9	13.7	13.6	13.2	12.9	12.0
32						13.7	13.5	13.4	13.2	13.1	13.0	12.8	12.7	12.6	12.4	12.3	11.9	11.6	10.8
34							12.3	12.2	12.0	11.9	11.8	11.6	11.5	11.4	11.2	11.1	10.7	10.4	9.7
36								11.2	11.0	10.9	10.8	10.6	10.5	10.4	10.2	10.1	9.7	9.4	8.7
38								10.3	10.1	10.0	9.9	9.7	9.6	9.5	9.3	9.2	8.8	8.5	7.8
40									9.4	9.3	9.2	9.0	8.9	8.8	8.6	8.5	8.1	7.8	7.1
42										8.6	8.5	8.3	8.2	8.1	7.9	7.8	7.4	7.1	6.4
44											7.9	7.7	7.6	7.5	7.3	7.1	6.8	6.5	5.8
46												7.0	6.9	6.8	6.6	6.5	6.1	5.8	5.1
48													6.4	6.3	6.2	6.0	5.9	5.5	4.5
50														5.8	5.7	5.5	5.4	5.0	4.0
52															5.2	5.0	4.9	4.5	3.5
54																4.5	4.4	4.0	3.0
56																	4.0	3.7	2.6
58																		3.0	2.3
60																			2.0

Note:

1. All rated loads are based on firm level ground, with 78% of tipping load at any point 360° around the machine and with front stability of 1.15 or more.
2. The weight of the sling, hook and auxiliary lifting devices are considered to be a part of the load:
 - Main hook 150 ton hook block 2,650 kg
 - Main hook 100 ton hook block 1,600 kg
 - Main hook 60 ton hook block 1,250 kg
 - Jib hook 13 ton hook block 500 kg
3. Recommended hoist cable parts:

For loads up to: Use:	For loads up to: Use:
10 ton-1 part line	86 ton-9 part line
19 ton-2 part line	95 ton-10 part line
29 ton-3 part line	105 ton-11 part line
38 ton-4 part line	114 ton-12 part line
48 ton-5 part line	124 ton-13 part line
57 ton-6 part line	133 ton-14 part line
67 ton-7 part line	143 ton-15 part line
76 ton-8 part line	150 ton-16 part line
4. The following weights must be reduced from the rated load when lifting by the main hook while the jib hook attached:
 - 1.5m jib boom 1,500 kg
 - 13m jib boom 2,910 kg
 - 19m jib boom 3,700 kg
 - 31m jib boom 5,800 kg
5. The total weight of the main hook and the jib hook must be reduced from the rated load when lifting by the jib hook while the main hook is attached.
6. 1.5m aux. jib can be attached 18 to 72m main boom. The rated loads for the 1.5m aux. jib must be reduced 900 kg from rated lifting load of the main boom.

7. The maximum main boom length to which jibs may be attached are as follows.
13m ~ 31m jibs can be attached to 45m ~ 69m booms.
8. Use the mast when the boom length is 69m and over. Intermediate boom-support pendant wire ropes should be use in combination with the mast when the boom length is 69m and over.
9. The allowable load for lifting by a jib at a radius from the center of rotation of the machine is the same load that may be lifted by the main boom with the boom lowered to that radius, but is not to exceed the following:

Jib length	1.5m	13m	19m	31m
15° jib offset	10.0 ton	13.0 ton	8.0 ton	3.0 ton
30° jib offset		9.0 ton	6.0 ton	2.6 ton

10. The angle formed by the extended centerline of the main boom and the centerline of the jib should not exceed 30° when a load is lifted.
11. Rated lifting loads marked with asterisks(*) are based on structural strength factors.
12. High-A-Frame should be extended before working.

Specially equipped Items (standard and optional specifications)

Standard specificaiton	Optional Specification
18m basic boom. 150 ton hook block. counterweight (50t) main hoist & boom hoist ropes. Safety devices. reclining seat. windshield wiper. radio. cigarette lighter. ash tray. head light. cab light. cab heater. step from crawler. step for climbing in to cab. crawler self dismantling device.	Insert boom (6m, 9m, 12m and 6m w/lug) 1.5m aux. jib. mast (for over 69m boom). Guide roller for insert boom. intermediate suspending device (for over 69m boom). basic fly jib (13m, 13 ton hook block. auxiliary hoist wire rope). insert jib (3m, 6m). 100 ton hook block. 60 ton hook block. 10 ton hook ball. car cooler. sling wire for shipping. (base machine complete). swing flashing signal light. moment limiter (over load prevention)

- The machine is manufactured in compliance with the Japanese Labor Ministry's "Structural Standards for Mobile Cranes" and it meets the requirements of "Safety Regulations for Crane and Related Machines".
- Specifications are subject to change without notice due to technical improvements or modifications.